

Pressure independent control valves (PICV), PN 25

VPP46.., VPP46..Q, VPI46.., VPI46..Q



VPP46..



VPI46..



VPP46..Q



VPI46..Q



For rooms, zones, ventilation and air-conditioning systems

- With integrated differential pressure controller
- DN 10...DN 32: Valve body made of dezincification resistant hot-pressed brass (DZR)
- DN 40...DN 50: Housing made of spheroidal graphite iron
- Volumetric flow 30...11500 l/h
- Differential pressure range 15...800 kPa
- Permissible medium temperature range 1...120° C
- Internally threaded Rp conforming to ISO 7-1
- Externally threaded G conforming to ISO 228-1
- Version with pressure test points for Δp measurement (optional)
- Can be equipped with electro thermal or electromotive actuator SSA..., SSD..., STA..65.. / STP..65.., SUA21/3P, SUE21P, SAY..1P03

Use

- In ventilation and air conditioning plants for control on the water side and automatic hydraulic balancing of terminal units, such as fan coils, induction units, and in heat exchangers for heating or cooling
- In heating zones like self-contained heating systems, apartments, individual rooms, etc.
- For closed circuits

Technical design

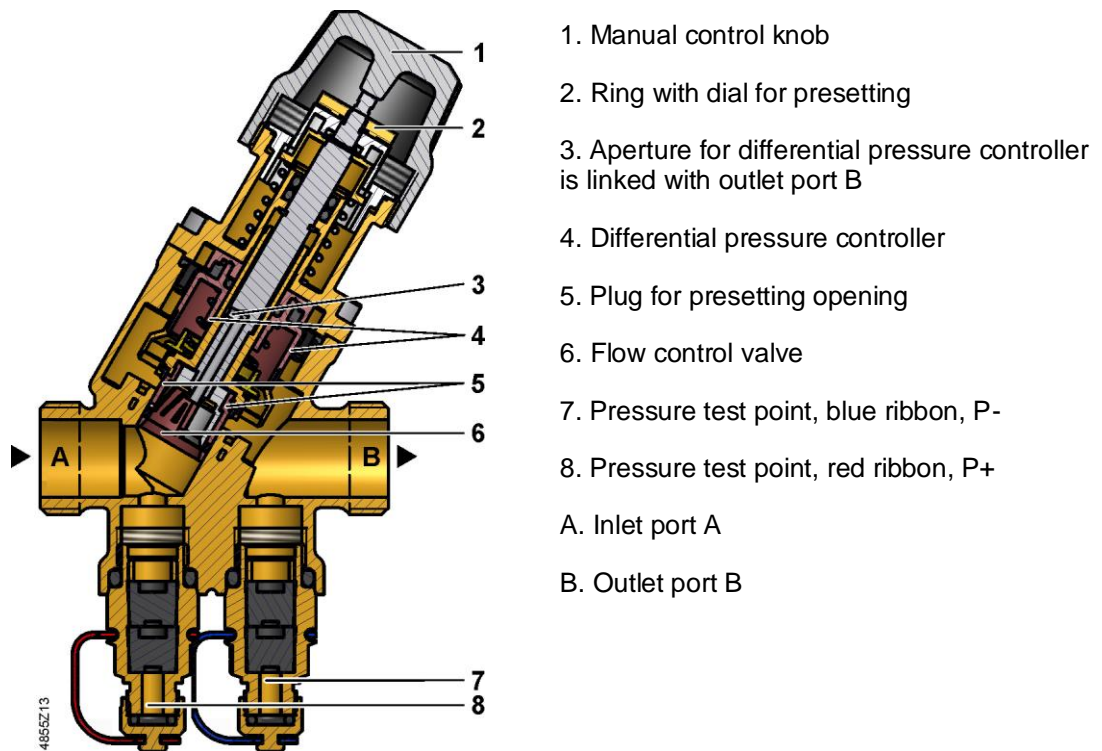

PICVs VPP46..Q (shown here) are additionally equipped with pressure test points P/T.

Functional principle

The medium entering the valve (inlet port A) passes through the variable presetting opening (5) which is connected to the ring with the dial (2) for presetting the desired maximum volumetric flow. Then, the medium flows through the flow control valve (6) with a linear characteristic and a stroke of 2.5 mm, 5 mm or 5.5 mm.

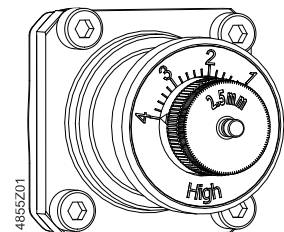

The actuator (not shown here) opens and accurately positions the control valve (6). Before leaving the PICV, the medium passes through a built-in mechanical differential pressure controller (4). This differential pressure controller is the heart of the PICV and ensures that the selected volumetric flow is maintained across the whole working range and independent of the inlet pressure p_1 .

The PICV VP..46..Q are additionally equipped with two pressure test points (P+, P-), which allow measurement of the differential pressure across the PICV. For that purpose, the electronic manometer ALE10 can be used.

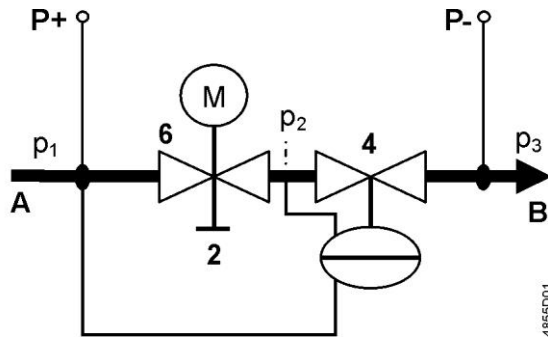

4855D01

- | | | | |
|---|---|-------|--|
| A | Inlet medium (inlet port) | P- | P/T port, pressure test point with blue ribbon (7) |
| B | Outlet medium (outlet port) | P+ | P/T port, pressure test point with red ribbon (8) |
| 2 | Ring with dial for presetting | p_1 | Pressure at inlet of PICV |
| 4 | Differential pressure controller maintains the pressure $p_1 - p_2$ constant across the flow control valve (6) and the presetting (2) | p_2 | Pressure at outlet of flow control valve |
| 6 | Control valve with mounted actuator | p_3 | Pressure at outlet of PICV |

Manual control DN 10...32

The manual control knob (1) is ready fitted to protect valve stem and preset mechanism and facilitates manual control of the PICV during commissioning.

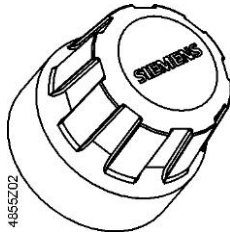

4855D02

Factory setting

The valve is open. The valve must be open to purge the system.
To close the valve, turn the manual knob clockwise.

Type summary

- VPP.. and VPI.. are without pressure test points P/T
- VPP..Q and VPI..Q are with pressure test points P/T

Type	Stock no.	DN	H ₁₀₀	External thread	\dot{V}_{min}	\dot{V}_{100}	Δp_{max}	SUA21/3P	SUE21P	ST..40..	ST..65..	SSA..	SSD..UT						
									Δp_s										
			[mm]	[inch]	[l/h]	[kPa]													
VPP46.10L0.2	S55264-V101	10	2.5	G ½ B	30	200	800	600	-	600	600	600	1380						
VPP46.10L0.4	S55264-V131		5		65	370		-	600	-									
VPP46.15L0.2	S55264-V102	15	2.5	G ¾ B	30	200		600	-	600				600	600	1380			
VPP46.15L0.4	S55264-V199		5		65	370		-	600	-									
VPP46.15L0.6	S55264-V103		2.5		100	575		600	-	600									
VPP46.15F1.4	S55264-V200		5		220	1330		-	600	-									
VPP46.20L0.6	S55264-V201	20	2.5	G 1 B	100	575		600	-	600				600	600	1380			
VPP46.20F1.4	S55264-V104		5		220	1330		-	600	-									
VPP46.20F1.8	S55264-V202		5.5		300	1800		-	600	-									
VPP46.25F1.8	S55264-V121	25	5	G 1¼ B	260	1670		-	600	-				-	-	-			
			5.5		280	1800		-	600	-				600	600	1380			
VPP46.25F3.6	S55264-V203		5		540	3284		-	600	-				-	-	-			
			5.5		600	3609		-	600	-				800	800	1380			
VPP46.32F4	S55264-V122	32	5	G 1½ B	510	3700		-	600	-				-	-	-			
			5.5		550	4001		-	600	-				800	800	-			
VPP46.10L0.2Q	S55264-V105	10	2.5	G ½ B	30	200		600	-	600				600	600	1380			
VPP46.10L0.4Q	S55264-V132		5		65	370		-	600	-									
VPP46.15L0.2Q	S55264-V106	15	2.5	G ¾ B	30	200		600	-	600							600	600	1380
VPP46.15L0.4Q	S55264-V189		5		65	370		-	600	-									
VPP46.15L0.6Q	S55264-V107		2.5		100	575		600	-	600									
VPP46.15F1.4Q	S55264-V190		5		220	1330		-	600	-									
VPP46.20L0.6Q	S55264-V191	20	2.5	G 1 B	100	575		600	-	600							600	600	1380
VPP46.20F1.4Q	S55264-V108		5		220	1330		-	600	-									
VPP46.20F1.8Q	S55264-V192		5.5		300	1800		-	600	-									
VPP46.25F1.8Q	S55264-V123	25	5	G 1¼ B	260	1670		-	600	-							-	-	-
			5.5		280	1800		-	600	-							600	600	1380
VPP46.25F3.6Q	S55264-V193		5		540	3284		-	600	-							-	-	
			5.5		600	3609		-	600	-							800	800	1380
VPP46.32F4Q	S55264-V124	32	5	G 1½ B	510	3700	-	600	-	-	-	-							
			5.5		550	4001	-	600	-	800	800	1380							

Type	Stock no.	DN	H ₁₀₀	Internal thread	v̇ _{min}	v̇ ₁₀₀	Δp _{max}	SUA21/3P	SUE21P	ST..40..	ST..65..	SSA..	SSD..UT
								Δp _s					
								[mm]	[inch]	[l/h]	[kPa]		
VPI46.15L0.2	S55264-V109	15	2.5	Rp ½	30	200	800	600	-	600	600	600	1380
VPI46.15L0.4	S55264-V204		5		65	370		-	600	-			
VPI46.15L0.6	S55264-V110		2.5		100	575		600	-	600			
VPI46.15F1.4	S55264-V205		5		220	1330		-	600	-			
VPI46.20L0.6	S55264-V206	20	2.5	Rp ¾	100	575		600	-	600	600	600	1380
VPI46.20F1.4	S55264-V111		5		220	1330		600	-	-			
VPI46.20F1.8	S55264-V207		5.5		300	1800		-	-	-			
VPI46.25F1.8	S55264-V125	25	5	Rp 1	260	1670		-	-	-	-	-	-
VPI46.25F3.6	S55264-V208		5.5		280	1800		-	-	600	600	1380	
			5		540	3284		-	600	-	-	-	
			5.5		600	3609		-	-	800	800	1380	
VPI46.32F4	S55264-V126	32	5	Rp 1½	510	3700		-	-	-	-	-	-
			5.5		550	4001	-	-	800	800	-	-	
VPI46.15L0.2Q	S55264-V112	15	2.5	Rp ½	30	200	600	-	600	600	600	1380	
VPI46.15L0.4Q	S55264-V194		5		65	370	-	600	-				
VPI46.15L0.6Q	S55264-V113		2.5		100	575	600	-	600				
VPI46.15F1.4Q	S55264-V195		5		220	1330	-	600	-				
VPI46.20L0.6Q	S55264-V196	20	2.5	Rp ¾	100	575	600	-	600	600	600	1380	
VPI46.20F1.4Q	S55264-V114		5		220	1330	600	-	-				
VPI46.20F1.8Q	S55264-V197		5.5		300	1800	-	-	-				
VPI46.25F1.8Q	S55264-V127	25	5	Rp 1	260	1670	-	-	-	-	-	-	
VPI46.25F3.6Q	S55264-V198		5.5		280	1800	-	-	600	600	1380		
			5		540	3284	-	600	-	-	-		
			5.5		600	3609	-	-	800	800	1380		
VPI46.32F4Q	S55264-V128	32	5	Rp 1½	510	3700	-	-	-	-	-	-	
			5.5		550	4001	-	-	800	800	1380		

Type	Stock no.	DN	H ₁₀₀	Internal thread	v̇ _{min}	v̇ ₁₀₀	SAY..P..	
							Δp _{min}	Δp _{max}
							[mm]	[inch]
VPI46.40F9.5Q	S55264-V129	40	15	Rp 1½	1370	9500	25	600
VPI46.50F12Q	S55264-V130	50		Rp 2	1400	11500	36	

DN = Nominal size

H₁₀₀ = Nominal stroke

v̇₁₀₀ = Volumetric flow through fully open valve (H₁₀₀)

\dot{V}_{\min} = Smallest pre-settable volumetric flow through fully open valve (H_{100})

Δp_{\max} = Maximum permissible differential pressure across the valves control path, valid for the entire actuating range of the motorized valve

Δp_s = Maximum permissible differential pressure at which the motorized valve will close securely against the pressure (close off pressure)

Δp_{\min} = Minimum differential pressure required across the valve's control path, so that the difference pressure regulator works reliably

Accessories

Type	Stock no.		Description
ALE10	BPZ:ALE10		Electronic manometer excluding measuring lines and measuring tips. Measuring range 0-700 kPa. A differential pressure of more than 1000 kPa will destroy the pressure sensor. For measuring the differential pressure between P+ and P- of the PICV see "Technical design [▶ 2]". Functions of the manometer: <ul style="list-style-type: none"> • Start/stop • Automatic zero position • Backlit display • Display: Out → outside the measuring range • Holding function
ALE11	BPZ:ALE11		Measuring lines and straight measuring tips for use with Siemens PICV. Equipped with G 1/8" connection with 2 x 40 mm needles.
ALP45	BPZ:ALP45		Spare nipples P/T port (set of 2) Set contains 1 piece each with a red and blue ribbon. Port: External threads G 1/8" to ISO 228 Connection to valve body: G 1/4" to ISO 228, inclusive O-ring Length: 40 mm
ALP46	S55264-V115		Blanking plug for P/T ports Connection to valve body: G 1/4" to ISO 228, inclusive O-ring
ALP47	S55264-V116		Drain ball valve inclusive O-ring Port: External threads G 1/2" to ISO 228 Connection to valve body: G 1/4" to ISO 228, inclusive O-ring Length: 48 mm
ALP48	S55264-V117		Combined P/T port and drain ball valve with red ribbon Port: External threads G 1/8" to ISO 228 Connection to valve body: G 1/4" to ISO 228, inclusive O-ring Length: 80 mm
ALP49	S55264-V118		Long P/T ports (set of 2 pieces) Set contains 1 piece each with a red and blue ribbon. Port: External threads G 1/8" to ISO 228 Connection to valve body: G 1/4" to ISO 228, inclusive O-ring Length: 120 mm
ALP50	S55264-V119		Spare black valve protection cap

Fittings

Type	Stock no.	Designation
ALG..2	BPZ:ALG..2	Set of 2 fittings with threaded connections for 2-port valves, consisting of 2 union nuts, 2 discs and 2 flat seals
ALG..2B	S55846-Z1..	Set of 2 brass fittings for medium temperatures up to 100° C, consisting of 2 union nuts, 2 discs and 2 flat seals
		See "Fittings [► 9]"

Insulation covers

Type	Stock no.	Designation
ALI20VPI46/VPP46	S55846-Z168	Insulation cover for VPP46.10.., VPI46.15.., VPP46.15.., VPI46.20.. and VPP46.20..
ALI25VPI46/VPP46	S55846-Z169	Insulation cover for VPI46.25F1.8.. and VPP46.25F1.8..
ALI32VPI46/VPP46	S55846-Z165	Insulation cover for VPI46.25F3.6.., VPP46.25F3.6.., VPI46.32.. and VPP46.32..
ALI50VPI46/VPP46	S55846-Z166	Insulation cover for VPI46.40.., VPP46.40, VPI46.50 and VPP46.50..



When using the insulation covers ALI..VPI46/VPP46 for comfort cooling applications, the insulation cover must be glued properly to the valve body, in order to minimize the risk of condensation between the valve and the insulation cover.

Delivery

Pressure independent control valves (PICV), actuators and accessories are packed and supplied separately.

Ordering Example

Type	Stock no.	Designation
VPP46.15L0.2	S55264-V102	PICV, PN 25, externally threaded
SSA331	S55180-A105	Actuator

Compatible actuators DN 15...32

Actuators	Operating voltage	Positioning		State without power ¹⁾	Fail-safe	Stroke	Connecting cable	Datasheet
		signal	force					
SSA131	AC 24 V	3-position	100 N	-	-	6.5 mm	1.5 m	A6V11858276
SSA331	AC 230 V							
SSA161.05	AC/DC 24 V	DC 0...10 V						
SSA151.05HF		DC 4...20 mA						
SSA161.05HF		DC 0...10 V						
SSA161E.05HF								
								A6V11858278

Actuators	Operating voltage	Positioning		State without power ¹⁾	Fail-safe	Stroke	Connecting cable	Datasheet					
		signal	force										
SSA118.09HKN	DC 24 V	KNX S-Mode KNX PL-Link						A6V11858280					
SSD131.09UT	AC 24 V	3-position	300 N		-		M16x1.5 threaded integrated conduit adapter cover, no cable						
SSD131.29UT					Yes								
SSD161S.05DUT	AC/DC 24 V	DC 0...10 V			-								
SSD161S.25DUT					Yes								
SUA21/3P	AC 230V	3-wire on/off (SPST)	100N	-		2.5 mm	0.8 m	A6V11780780					
SUE21P	AC 230V					5 mm		A6V11780777					
STA121.65L10	AC/DC 24 V	2-position	125 N	NC	-	6,5 mm	1 m	A6V14028280					
STA121.65L20						2 m							
STA121.65H20						2 m halogen-free							
STA121.65/00						-							
STA321.65L10	1 m												
STA321.65L20	2 m												
STA321.65H20	2 m halogen-free												
STA321.65/00	-												
STP121.65L10	AC/DC 24 V		1 m										
STP121.65L20			2 m										
STP121.65/00			-										
STP321.65L10	AC 230 V		1 m										
STP321.65L20			2 m										
STP321.65/00			-										
STA161.65L10	AC 24 V		DC 0...10 V							1 m			
STA162.65L10	AC/DC 24 V										NC		
STP161.65L10		NO											
STP162.65L10													
STA121.40L10	AC/DC 24 V	2-position	100 N			4 mm	1 m						
STP121.40L10								NC					
STA321.40L10	AC 230 V							NO					
STP321.40L10								NO					
STA126.40L10	AC/DC 24 V							NO					
STA326.40L10	AC 230 V												
STA161.40L10	AC 24 V							DC 0...10 V					
STP161.40L10													

¹⁾ NC = Normally Closed = VPP46../VPI46.. powerless closed
NO = Normally Open = VPP46../VPI46.. powerless open
The valve is fully opened without an actuator.

Compatible actuators DN 40...50

Type	Stock no.	Operating voltage	Positioning			Fail-safe	Stroke	Manual adjustment	Aux. funct.	Datasheet	
			signal	force	time						
SAY31P03	S55150-A132	AC 230 V	3-position	200 N	30 s	-	15 mm	Press and fix in place	1)	A6V10628469	
SAY61P03	S55150-A133	AC/DC 24 V	DC 0...10 V DC 4...20 mA 0...1000 Ω						2)		3)
SAY81P03	S55150-A134		3-position						1)		

1) Optional accessories: Auxiliary switch ASC10.51

2) Positioning feedback, forced control, characteristic curve changeover

3) Optional accessories: Auxiliary switch ASC10.51, sequence control, control action changeover AZX61.1

Fittings



PICV		Set of fittings			
Externally threaded		Malleable cast iron		Brass	
Type	Stock no.	Type	Stock no.	Type	Stock no.
VPP46.10L0.2	S55264-V101	-	-	ALG132 ¹⁾	BPZ:ALG132
VPP46.10L0.4	S55264-V131	-	-	ALG132 ¹⁾	BPZ:ALG132
VPP46.15L0.2	S55264-V102	-	-	ALG142 ¹⁾	BPZ:ALG142
VPP46.15L0.4	S55264-V199	-	-	ALG142 ¹⁾	BPZ:ALG142
VPP46.15L0.6	S55264-V103	-	-	ALG142 ¹⁾	BPZ:ALG142
VPP46.15F1.4	S55264-V200	-	-	ALG142 ¹⁾	BPZ:ALG142
VPP46.20L0.6	S55264-V201	ALG152	BPZ:ALG152	ALG152B ²⁾	S55846-Z100
VPP46.20F1.4	S55264-V104	ALG152	BPZ:ALG152	ALG152B ²⁾	S55846-Z100
VPP46.20F1.8	S55264-V202	ALG152	BPZ:ALG152	ALG152B ²⁾	S55846-Z100
VPP46.25F1.8	S55264-V121	ALG202	BPZ:ALG202	ALG202B ²⁾	S55846-Z102
VPP46.25F3.6	S55264-V203	ALG202	BPZ:ALG202	ALG202B ²⁾	S55846-Z102
VPP46.32F4	S55264-V122	ALG252	BPZ:ALG252	ALG252B ²⁾	S55846-Z104
VPP46.10L0.2Q	S55264-V105	-	-	ALG132 ¹⁾	BPZ:ALG132
VPP46.10L0.4Q	S55264-V132	-	-	ALG132 ¹⁾	BPZ:ALG132
VPP46.15L0.2Q	S55264-V106	-	-	ALG142 ¹⁾	BPZ:ALG142
VPP46.15L0.4Q	S55264-V189	-	-	ALG142 ¹⁾	BPZ:ALG142
VPP46.15L0.6Q	S55264-V107	-	-	ALG142 ¹⁾	BPZ:ALG142
VPP46.15F1.4Q	S55264-V190	-	-	ALG142 ¹⁾	BPZ:ALG142
VPP46.20L0.6Q	S55264-V191	ALG152	BPZ:ALG152	ALG152B ²⁾	S55846-Z100
VPP46.20F1.4Q	S55264-V108	ALG152	BPZ:ALG152	ALG152B ²⁾	S55846-Z100
VPP46.20F1.8Q	S55264-V192	ALG152	BPZ:ALG152	ALG152B ²⁾	S55846-Z100

PICV		Set of fittings			
Externally threaded		Malleable cast iron		Brass	
Type	Stock no.	Type	Stock no.	Type	Stock no.
VPP46.25F1.8Q	S55264-V123	ALG202	BPZ:ALG202	ALG202B ²⁾	S55846-Z102
VPP46.25F3.6Q	S55264-V193	ALG202	BPZ:ALG202	ALG202B ²⁾	S55846-Z102
VPP46.32F4Q	S55264-V124	ALG252	BPZ:ALG252	ALG252B ²⁾	S55846-Z104

- 1) Connecting thread pipe side: Internally threaded
2) Usable up to maximum medium temperature of 100 °C



Notes

Safety

 CAUTION	
	<p>National safety regulations</p> <p>Failure to comply with national safety regulations may result in personal injury and property damage.</p> <ul style="list-style-type: none"> Observe national provisions and comply with the appropriate safety regulations.

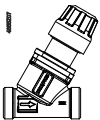
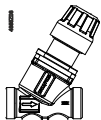
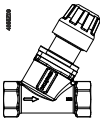
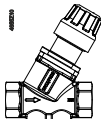
Engineering

Valve	Symbols / Direction of flow		Flow in control mode	Valve stem	
	VP..46..	VP..46..Q		retracts	extends
VPP46..			variable	closes	opens
VPI46..					

 WARNING	
	<p>The direction of flow indicated (arrow on the valve body) is mandatory!</p> <p>The valves should preferably be mounted in the return pipe where temperatures are lower and where the sealing gland is less affected by strain.</p>

Symbol used in catalogs and application descriptions	Symbol used in diagrams
	There are no standard symbols for PICV in diagrams.

Recommendation

A strainer or dirt trap should be fitted upstream of the valve to enhance reliability. Remove dirt, welding beads etc. from valves and pipes. Do not insulate the actuator bracket, as air circulation must be ensured!

Mounting

PICV and actuator can be straightforwardly assembled on site. Special tools or adjustments are not required. Prior to mounting the actuator, the required volumetric flow must be set. The valve is supplied complete with Mounting Instructions (74 319 0649 0).

Mounting positions

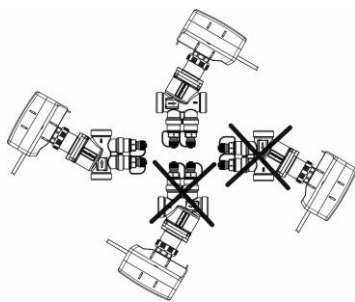

SUA21/3P, SUE21P

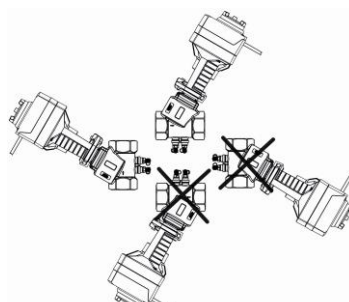

SAY.. indoor, SSD..UT

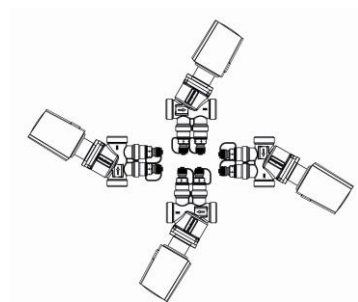

STA..65.., STP..65.., SSA..

Actuators STA..65.., STP..65.. and SSA.. may be installed in any position. Actuators SUA21/3P, SUE21P must be installed horizontally up to 90° and not hanging. Actuators SSD..UT and SAY.. cannot be installed upside down. In case actuators SSD..UT and SAY.. are installed horizontally and hanging, the cable must always be installed pointing downwards. Otherwise, the IP protection is not guaranteed, as water running down the cable might enter the actuator.

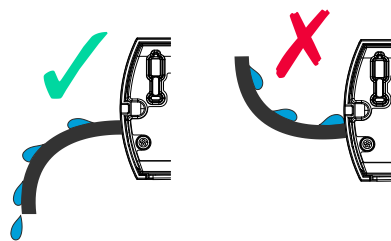

Installation

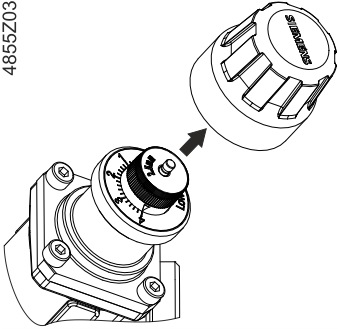
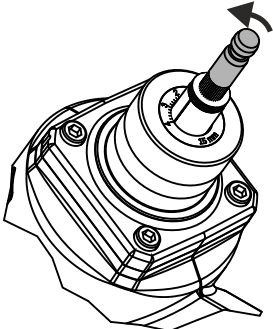
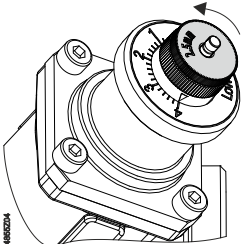
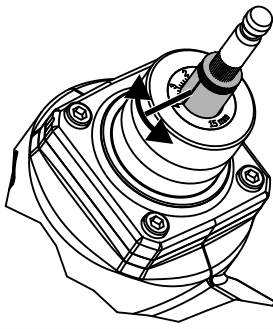
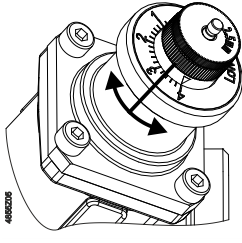
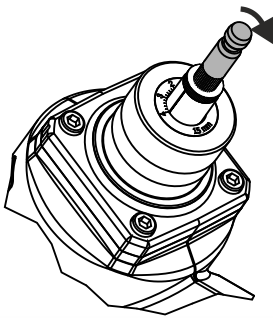
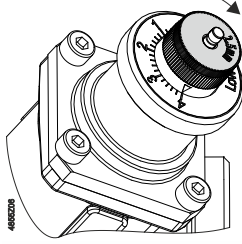
Presetting DN 10...32:	Presetting DN 40...50:
<p>1. Remove control knob from PICV.</p> <p>4855Z03</p> 	<p>1. Loosen spindle head.</p> 
<p>2. Loosen knurled nut.</p> <p>4855Z04</p> 	<p>2. Adjust the desired dial setting with the white knob.</p> 
<p>3. Adjust the desired dial setting with the white knob.</p> <p>4855Z05</p> 	<p>3. Retighten spindle head - by hand only.</p> 
<p>4. Retighten knurled nut by hand.</p> <p>4855Z06</p> 	

Commissioning

⚠ WARNING	
	<p>The valves must be commissioned with the manual control knob or actuator correctly fitted. Strong pressure impacts can damage closed PICV.</p>

⚠ WARNING



The PICV have to be open when flushing or pressure testing the system.
Flush only in correct flow direction. Strong pressure impacts can damage closed PICV.

⚠ WARNING



Differential pressure Δp_{\max} across the valve's control path is not allowed to exceed 800 kPa.

Manual control

When turning the manual control knob in counter-clockwise direction or manually operating the actuator, the valve opens. The actuator closes the valve. The valves are supplied fully open. The manual knob is not designed for permanent manual operation.

Maintenance

- The VP..46.. PICV valves are maintenance-free without cartridge.
- Valve plug, stem, presetting, diaphragm etc. may not be disassembled

When performing service work on the valve and / or actuator:

- Switch off the pump and disconnect power supply.
- Close the shut-off valves in the piping network.
- Fully reduce pressure in the piping network and allow the pipes to cool down completely.
- Remove the electrical connections only if necessary.

Sealing gland

The stem sealing gland cannot be exchanged. Should leakage occur, the whole valve must be replaced.

Disposal



This symbol or any other national label indicate that the product, its packaging, and, where applicable, any batteries may not be disposed of as domestic waste. Delete all personal data and dispose of the item(s) at separate collection and recycling facilities in accordance with local and national legislation.

For additional details, refer to [Siemens information on disposal](#).

Warranty

Technical data on specific applications are valid only together with Siemens products listed under "Equipment combinations". Siemens rejects any and all warranties in the event that third-party products are used.

Functional data	
PN class	PN 25 as per EN 1333
Permissible operating pressure	2.500 kPa (25 bar) as per ISO 7628 / EN 1333 Max. differential pressure: 800 kPa Min. differential pressure: See "Volumetric flow/dial presetting [► 16]"
Valve characteristic	Linear as per VDI/VDE 2173
Leakage rate	General: Class IV (0...0.01% of volumetric flow V_{100}) to EN 1349 DN 25...32 with STA...3...: Class III (0...0,1% of volumetric flow V_{100}) per EN 1349
Average flow accuracy	+/-10% from Δp_{\min} to $2.5 \times \Delta p_{\min}$ +/- 5% from $2.5 \times \Delta p_{\min}$ to 800 kPa
Permissible media	Low-temperature hot water, chilled water, water with antifreeze Recommendation: Water treatment to VDI 2035
Medium temperature	1...120 °C for valve with actuator 1...110 °C with SUA21/3P, SUE21P actuators
Permissible ambient temperature	1...50 °C
Nominal stroke	DN 10L0.2, DN 15L0.2, DN 15L0.6: 2.5 mm DN 10L0.4 / DN 20: 5 mm DN 25...32: 5.5 mm DN 40...50: 15 mm

Materials	
Valve body, port, seat, sealing gland and test points	Dezincification resistant hot-pressed brass (DZR), CW602N Valve body DN 40...50: Nodular cast iron
Stem, spring	Stainless steel
Presetting element	PTFE, PPO, POM C and ABS
Regulator	PPS
Seals	EPDM 281 (O-ring)

Insulation covers	ALI20VPI46/VPP46, ALI25VPI46/VPP46, ALI32VPI46/VPP46	ALI50VPI46/VPP46
Materials	EPP (Expanded Polypropylene)	EPE (Crosslinked Expanded Polyethylene)
Water absorption	< 2.5 vol% at 20° C	< 1 vol% at 20° C
Temperature range	Up to 120° C	Up to 90° C
Insulating property (Lambda)	0.039 W/mK	0.041 W/mK
Density	30 g/l	30 g/l
Flammability	DIN 4102: B2	DIN 4102: B2

Connections	
Threaded connections	VPP46...: G..B to ISO 228-1 (externally threaded) VPI46...: Rp to ISO 7-1 (internally threaded)
Actuator connection	DN 10...32: M30 x 1.5 mm DN 40...50: Siemens large stroke connector
Pressure test points (P/T-ports)	G 1/4" (connection valve body) 2 mm x 40 mm (needles)

Dimensions
For dimensions and weight refer to "Dimensions [▶ 19]".

Standards, directives and approvals	
EU conformity (CE)	DN 10...40: Without CE-marking DN 50: CE 1T4855xx (A5W00022837) ¹⁾
EAC conformity	Eurasian conformity
Pressure Equipment Directive	PED 2014/68/EU
	Pressure accessories
	Fluid group 2
	Environmental compatibility

Scope: Article 1, section 1
Definitions: Article 2, section 5

DN 10...40: Without CE-marking as per article 4, section 3 (sound engineering practice)
DN 50: Category I, Module A, with CE-marking as per article 14, section 2

The product environmental declaration CE 1E4855en ¹⁾ contains data on environmentally compatible product design and assessments (RoHS compliance, materials composition, packaging, environmental benefit, disposal).

¹⁾ The documents can be downloaded at <http://www.siemens.com/bt/download>.

Sizing

Engineering Basis of calculation

1. Determine energy demand Q [kW]
2. Determine temperature differential ΔT [K]
3. Calculate volumetric flow

$$\dot{v} = \frac{Q[\text{kW}] \cdot 1000}{1,163 \cdot \Delta T[\text{K}]} \left[\frac{\text{l}}{\text{h}} \right]$$

4. Select suitable PICV
pipe connections (internally or externally threaded)
with or without P/T ports
5. Determine dial setting using volumetric flow/dial presetting table, see the following page

Example

1. Given is a heat exchanger with $Q = 1.9 \text{ kW}$
2. Temperature differential (supply - return) $\Delta T = 6 \text{ K}$
3. Volumetric flow

$$\dot{v} = \frac{1,9 \text{ kW} \cdot 1000}{1,163 \cdot 6 \text{ K}} = 272,28 \text{ l/h}$$

Hint: You can also determine the volumetric flow using the valve slide rule.

4. The valve shall have connections with external threads to ISO 228-1 and size DN 15.
5. PICV selection:
Ideally, PICV should be selected such that they operate at about 80% of their maximum flow, enabling them to deliver spare capacity, if required. VPP46.15L0.6 (externally threaded connections, no pressure test points P/T, nominal volumetric flow 600 l/h)
6. Determine dial setting using volumetric flow/dial presetting table below:
Volumetric flow 270 l/h
Dial setting 1.8

Valve characteristic VP..46..., VP..46..Q

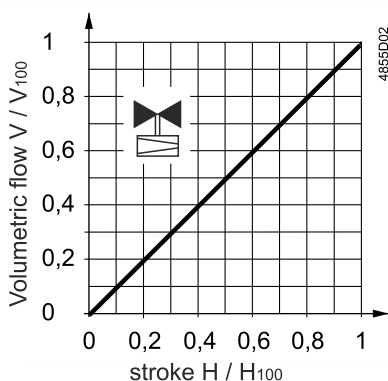

Volumetric flow/dial presetting

- Tables to determine the dial setting for a desired volumetric flow.
- Δp_{\min} [kPa] based on volumetric flow; interpolate missing values.



The presetting tables indicate the expected nominal volumetric flow. During commissioning, check whether current pre-settings correspond to the planned design. Further adjustment of the pre-settings may be required to achieve the needed volumetric flow.

Presetting range linear to VDI/VDE 2173

 Presetting range linear

 Presetting range not permitted

VPP46.10L0.2, VPP46.10L0.2Q, VPP46.15L0.2, VPP46.15L0.2Q, VPI46.15L0.2, VPI46.15L0.2Q																	200 l/h nominal ¹⁾			
[l/h]		30	35	40	50	60	70	80	90	100	110	120	130	140	150	160	170	180	190	200
Dial	Min	0.5	0.6	0.8	1	1.2	1.4	1.6	1.8	2	2.2	2.4	2.6	2.8	3	3.2	3.4	3.6	3.8	Max
Δp_{\min} ³⁾		14.3	14.3	14.3	14.5	14.6	14.6	14.7	14.8	14.9	15	15.1	15.2	15.3	15.4	15.5	15.5	15.6	15.7	15.8

VPP46.10L0.4, VPP46.10L0.4Q, VPP46.15L0.4, VPP46.15L0.4Q, VPI46.15L0.4, VPI46.15L0.4Q																	370 l/h nominal ²⁾		
[l/h]	█	65	83	101	119	137	155	179	191	209	226	244	262	280	298	316	334	352	370
Dial	Min	0.6	0.8	1	1.2	1.4	1.6	1.8	2	2.2	2.4	2.6	2.8	3	3.2	3.4	3.6	3.8	Max
$\Delta p_{min}^{3)}$		14.6	14.8	14.9	15.1	15.3	15.4	15.6	15.7	15.9	16	16.2	16.3	16.5	16.6	16.7	16.9	17	17.2

VPP46.15L0.6, VPP46.15L0.6Q, VPI46.15L0.6, VPI46.15L0.6Q, VPP46.20L0.6, VPP46.20L0.6Q, VPI46.20L0.6, VPI46.20L0.6Q																	600 l/h nominal ¹⁾			
[l/h]	█	100	115	130	160	180	210	240	270	300	320	350	380	410	440	460	490	520	550	575
Dial	Min	0.5	0.6	0.8	1	1.2	1.4	1.6	1.8	2	2.2	2.4	2.6	2.8	3	3.2	3.4	3.6	3.8	Max
$\Delta p_{min}^{3)}$		14.9	15.2	15.5	15.6	15.9	16.1	16.4	16.6	16.8	17	17.2	17.5	17.6	17.8	18	18.2	18.4	18.6	18.9

VPP46.15F1.4, VPP46.15F1.4Q, VPI46.15F1.4, VPI46.15F1.4Q, VPP46.20F1.4, VPP46.20F1.4Q, VPI46.20F1.4, VPI46.20F1.4Q																	1400 l/h nominal ²⁾		
[l/h]	█	220	290	350	420	480	550	610	680	740	810	870	940	1000	1070	1130	1200	1260	1330
Dial	Min	0.6	0.8	1	1.2	1.4	1.6	1.8	2	2.2	2.4	2.6	2.8	3	3.2	3.4	3.6	3.8	Max
$\Delta p_{min}^{3)}$		16	16.5	17	17.5	17.9	18.4	18.8	19.2	19.5	19.9	20.2	20.4	20.7	20.9	21.1	21.3	21.4	21.6

VPP46.20F1.8, VPP46.20F1.8Q, VPI46.20F1.8, VPI46.20F1.8Q, VPP46.25F1.8, VPP46.25F1.8Q, VPI46.25F1.8, VPI46.25F1.8Q																	1800 l/h nominal ²⁾		
[l/h]	█	280	356	430	502	574	647	722	800	881	967	1057	1151	1250	1353	1460	1571	1685	1800
Dial	Min	0.6	0.8	1	1.2	1.4	1.6	1.8	2	2.2	2.4	2.6	2.8	3	3.2	3.4	3.6	3.8	Max
$\Delta p_{min}^{3)}$		15.3	15.8	16.1	16.4	16.7	17	17.5	18	18.7	19.7	20.9	22.3	24.2	26.4	28.9	32.0	35.4	39.4

VPP46.25F3.6, VPP46.25F3.6Q, VPI46.25F3.6, VPI46.25F3.6Q																	3600 l/h nominal ²⁾		
[l/h]	█	600	777	954	1131	1308	1485	1662	1839	2016	2193	2370	2547	2724	2901	3078	3255	3432	3609
Dial	Min	0.6	0.8	1	1.2	1.4	1.6	1.8	2	2.2	2.4	2.6	2.8	3	3.2	3.4	3.6	3.8	Max
$\Delta p_{min}^{3)}$		17	17	17	18	18	18	18	18	18	18	19	19	20	20	21	21	22	23

VPP46.32F4, VPP46.32F4Q, VPI46.32F4, VPI46.32F4Q																	4000 l/h nominal ²⁾		
[l/h]	█	550	800	910	1110	1320	1520	1720	1930	2130	2330	2530	2740	2940	3140	3350	3550	3750	4001
Dial	Min	0.6	0.8	1	1.2	1.4	1.6	1.8	2	2.2	2.4	2.6	2.8	3	3.2	3.4	3.6	3.8	Max
$\Delta p_{min}^{3)}$		17.9	18	18.1	18.2	18.3	18.5	18.7	18.9	19.2	19.6	20.1	20.7	21.4	22.3	23.4	24.6	26	28

VPI46.40F9.5Q																	9500 l/h nominal ²⁾		
[l/h]	█	1370	1600	1950	2250	2650	3000	3400	3800	4250	4750	5250	5800	6350	6950	7550	8200	8800	9500
Dial	Min	0.6	0.8	1	1.2	1.4	1.6	1.8	2	2.2	2.4	2.6	2.8	3	3.2	3.4	3.6	3.8	Max
$\Delta p_{min}^{3)}$		10	10	10	10	10	10	10	11	11	12	13	15	16	18	20	22	24	25

VPI46.50F12Q																	11500 l/h nominal ²⁾		
[l/h]	█	1400	1650	2000	2350	2700	3150	3550	4050	4600	5150	5800	6500	7300	8150	9000	9800	10600	11500
Dial	Min	0.6	0.8	1	1.2	1.4	1.6	1.8	2	2.2	2.4	2.6	2.8	3	3.2	3.4	3.6	3.8	Max
$\Delta p_{min}^{3)}$		10	10	11	11	11	12	12	13	14	15	17	19	21	24	27	30	33	36

- 1) The presetting range for 0.2 and 0.4 is not permitted.
- 2) The presetting range for 0.2, 0.4 and 0.5 is not permitted.
- 3) Δp_{\min} in [kPa]

Application examples

PICV in HVAC systems combined with variable speed pumps provide even higher energy efficiency. When sizing the pump, it must be made certain that the most critical branch or consumer in the system – usually the remotest from the pump – gets enough pressure (pump head). Thus, it is recommended to use a variable speed pump in constant-pressure mode with end-point feedback, to maintain a minimum differential pressure across the critical valve.

Residential buildings

Residential buildings with for example self-contained flat heating systems:

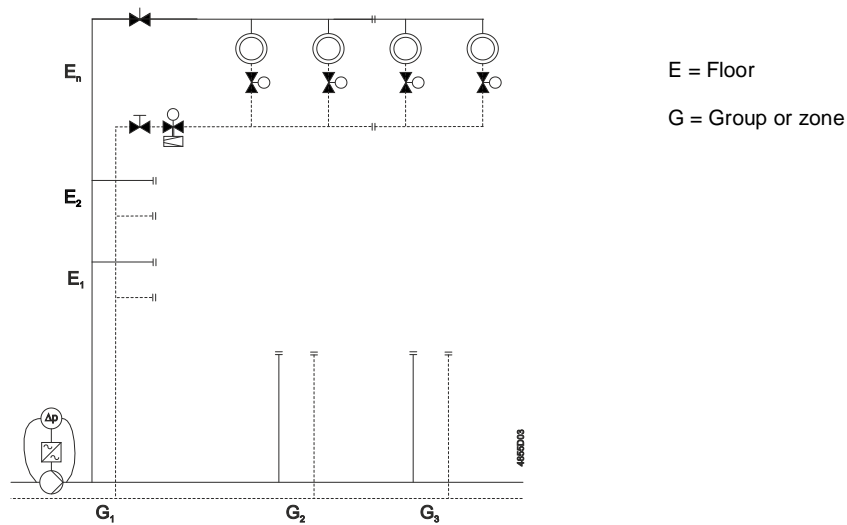

Non-residential buildings

Commercial buildings with for example Fan Coil Units or heat exchangers for heating or cooling:

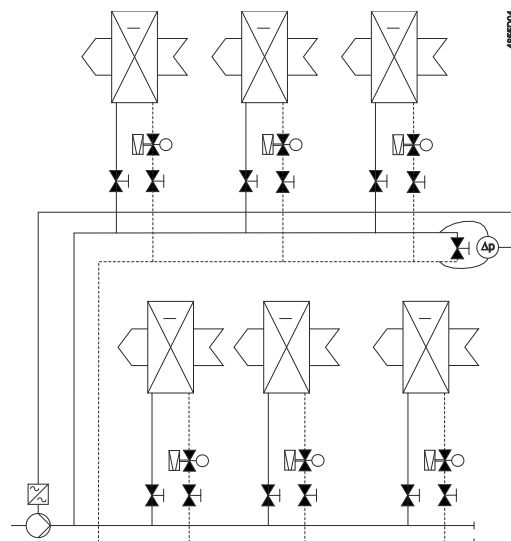

Dimensions

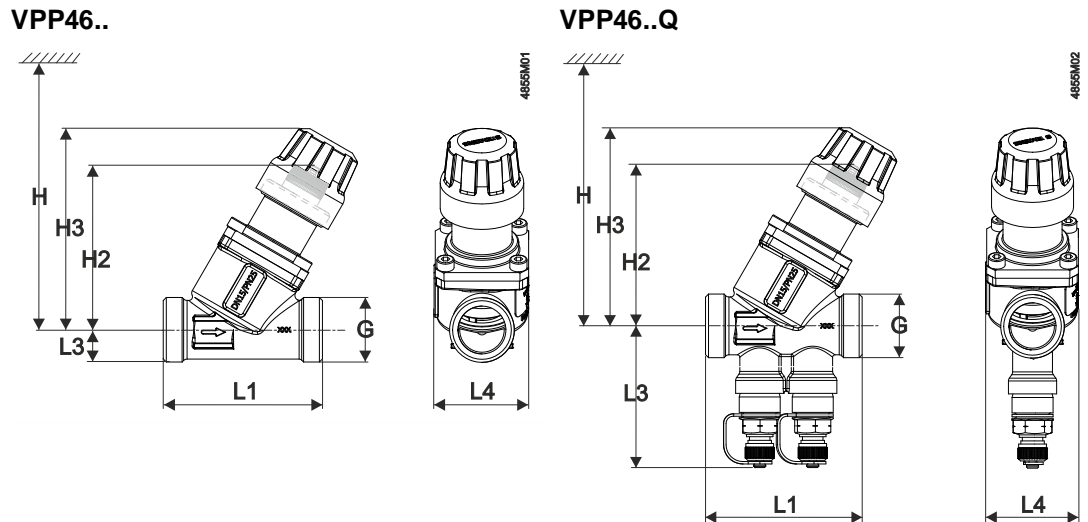

Type	DN	G	L1	L3	L4	H2	H3	H ¹⁾					kg	
								SSA..	STA..40.. / STP..40..	STA..65.. / STP..65..	SUA21/3P	SUE21P	SSD..UT	
								[mm]						[kg]
[inch]		[mm]										[kg]		
VPP46.10L0.2	10	½	65	10.5	38	68.5	83.5	170	160	160	134	134	371	0.314
VPP46.10L0.4									-					
VPP46.15L0.2	15	¾	65	13.2	38	67.3	82.2	170	160	160	135	135	374	0.333
VPP46.15L0.4									-					
VPP46.15L0.6									160					
VPP46.15F1.4									-					
VPP46.20L0.6	20	1	70	13.6	63	67.5	82.5	185	160	175	155	155	391	1.22
VPP46.20F1.4									-					
VPP46.20F1.8									-					
VPP46.25F1.8	25	1¼	104	78	63	70	85	185	-	175	155	155	391	1.02
VPP46.25F3.6				22		-								
VPP46.32F4	32	1½	104	26	63	85	100	185	-	175	155	155	391	1.22
VPP46.10L0.2Q	10	½	65	54.8	38	68.5	83.5	170	160	160	134	134	371	0.402
VPP46.10L0.4Q									-					0.302
VPP46.15L0.2Q	15	¾	65	55.5	38	67.3	82.2	170	160	160	135	135	374	0.422
VPP46.15L0.4Q									-					
VPP46.15L0.6Q									160					
VPP46.15F1.4Q									-					
VPP46.20L0.6Q	20	1	70	57.3	63	67.5	82.5	185	160	175	155	155	391	1.02
VPP46.20F1.4Q									-					
VPP46.20F1.8Q									-					

Type	DN	G	L1	L3	L4	H2	H3	H ¹⁾						kg
								SSA..	STA..40.. / STP..40..	STA..65.. / STP..65..	SUA21/3P	SUE21P	SSD..UT	
								[mm]						
VPP46.25F1.8Q	25	1¼	78	59		70	85			138	138	385	0.59	
VPP46.25F3.6Q				63						175	155	155	391	1.12
VPP46.32F4Q	32	1½	104	68	63	85	100	185		175	155	155	391	1.317

1) Total height including actuator

VPI46..

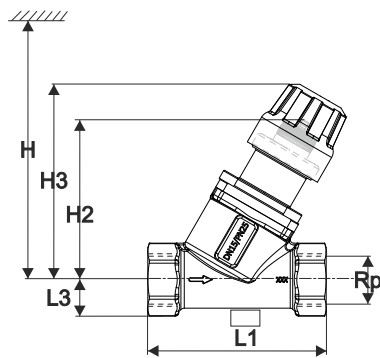

VPI46..Q

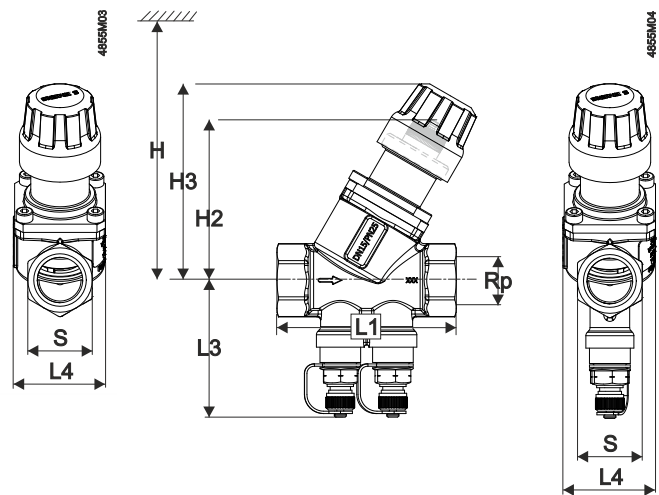

Type	DN	Rp	S	L1	L3	L4	H2	H3	H ¹⁾						kg	
									SSA..	ST..40..	ST..65..	SAY..	SUA21/3P	SUE21P		SSD..UT
									[mm]							[inch]
VPI46.15L0.2	15	½	27	75	15.2		67.3	82.4	160	160	135	135	374	0.377		
VPI46.15L0.4									-							
VPI46.15L0.6									160							
VPI46.15F1.4									-							
VPI46.20L0.6	20	¾	32	79	17.9	38	67.5	82.5	160	160	135	135	374	0.418		
VPI46.20F1.4									-							
VPI46.20F1.8									-							
VPI46.25F1.8	25	1	39	83	22	63	85	100	185	175	155	155	391	0.533		
VPI46.25F3.6				100										1.04		
VPI46.32F4	32	1½	46	104	26									1.219		
VPI46.15L0.2Q	15	½	27	75	60.2	38	67.3	82.4	160	160	135	135	374	0.477		
VPI46.15L0.4Q									-							
VPI46.15L0.6Q									160							
VPI46.15F1.4Q									-							

Type	DN	Rp	S	L1	L3	L4	H2	H3	H ¹⁾						kg
									SSA..	ST..40..	ST..65..	SAY..	SUA21/3P	SUE21P	
									[inch]	[mm]					
VPI46.20L0.6Q	20	¾	32	79	62.9		67.5	82.5	160						0.506
VPI46.20F1.4Q									-	-	-	-	-	-	
VPI46.20F1.8Q															
VPI46.25F1.8Q	25	1	39	83	59	63	70	85	-	175	138	138	385	0.625	
VPI46.25F3.6Q				100	63		185	155			155	391	1.14		
VPI46.32F4Q	32	1¼	46	104	68	63	85	100	185	-	-	-	-	1.316	
VPI46.40F9.5Q	40	1½	56	138	71	90	161	-	-	-	500	-	-	-	3.253
VPI46.50F12Q	50	2	70		77		-	-	-			-	-	3.683	

1) Total height including actuator

Accessories

Fittings

ALG132, ALG142

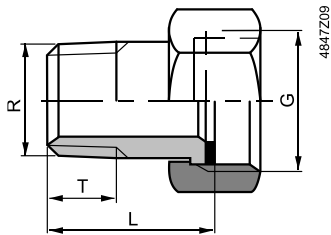

ALG15.., ALG20.., ALG25..

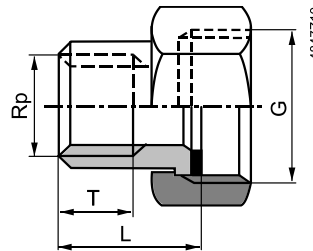

ALG.. type		For valve type	DN	G	R	Rp	L	T
Malleable cast iron	Brass ¹⁾			[inch]			[mm]	
-	ALG132 ²⁾	VPP46.10..	10	G ½ B	R ¾	-	≈ 24	≈ 9
-	ALG142 ²⁾	VPP46.15..	15	G ¾ B	R ½	-	≈ 29.5	≈ 12
ALG152 ³⁾	ALG152B ³⁾	VPP46.20..	20	G 1 B	-	Rp ½	≈ 23	≈ 13
ALG202 ³⁾	ALG202B ³⁾	VPP46.25..	25	G 1¼ B	-	Rp ¾	-	-
ALG252 ³⁾	ALG252B ³⁾	VPP46.32..	32	G 1½ B	-	Rp 1	-	-

- Sets of 2 threaded fittings with flat seal
- Valve side: cylindrical thread to ISO 228-1
- Pipe side: with cylindrical thread to ISO 7-1

1) Maximum medium temperature 100 °C

2) Pipe side with external R threads

3) Pipe side with internal Rp threads

Insulation covers

ALI20VPI46/VPP46, ALI25VPI46/VPP46,
ALI32VPI46/VPP46

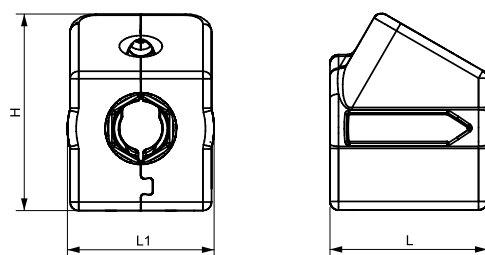

ALI50VPI46/VPP46

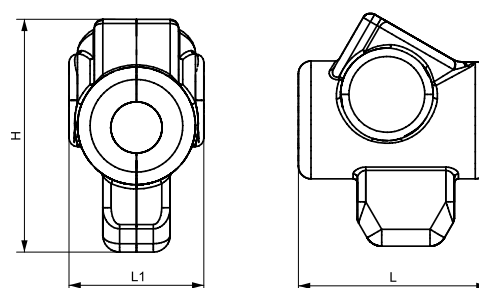

ALI. type	For valve type	L	L1	H	kg
		[mm]			[kg]
ALI20VPI46/VPP46	VP..46.10, VP..46.15.. VP..46.20	91	85	114	0.034
ALI25VPI46/VPP46	VP..46.25F1.8	102	119	134	0.056
ALI32VPI46/VPP46	VP..46.25F3.6, VP..46.32..	115	131	165	0.083
ALI50VPI46/VPP46	VP..46.40.., VP..46.50..	225	160	280	0.185

Revision numbers

Type	Valid from rev. no.	Type	Valid from rev. no.
VPP46.10L0.2	..A	VPP46.10L0.2Q	..A
VPP46.10L0.4	..B	VPP46.10L0.4Q	..B
VPP46.15L0.2	..A	VPP46.15L0.2Q	..A
VPP46.15L0.6	..A	VPP46.15L0.6Q	..A
VPP46.20F1.4	..A	VPP46.20F1.4Q	..A
VPP46.25F1.8	..A	VPP46.25F1.8Q	..A
VPP46.32F4	..A	VPP46.32F4Q	..A
VPI46.15L0.2	..A	VPI46.15L0.2Q	..A
VPI46.15L0.6	..A	VPI46.15L0.6Q	..A
VPI46.20F1.4	..A	VPI46.20F1.4Q	..A
VPI46.25F1.8	..A	VPI46.25F1.8Q	..A
VPI46.32F4	..A	VPI46.32F4Q	..A
-	-	VPI46.40F9.5Q	..A
-	-	VPI46.50F12Q	..A

Documentation form

Installed location	Valve type	Actuator type	Valve size	Planned pre-setting	Required Δp_{min}	Verified Δp	Flow ¹⁾
					[kPa]	[l/h]	

¹⁾ If verified $\Delta p >$ required Δp_{min} , then flow is as per presetting in datasheet; otherwise check.

Issued by
Siemens Switzerland Ltd
Smart Infrastructure
Global Headquarters
Theilerstrasse 1a
CH-6300 Zug
+41 58 724 2424
www.siemens.com/buildingtechnologies

© Siemens 2011 - 2025
Technical specifications and availability subject to change without notice.

Document ID CE1N4855en
Edition 2025-03-17